

Questionnaire Form for lattice boom crane

1. Crane model and year: _____
2. Manufacturing company: _____
3. Enter the following dimensions:

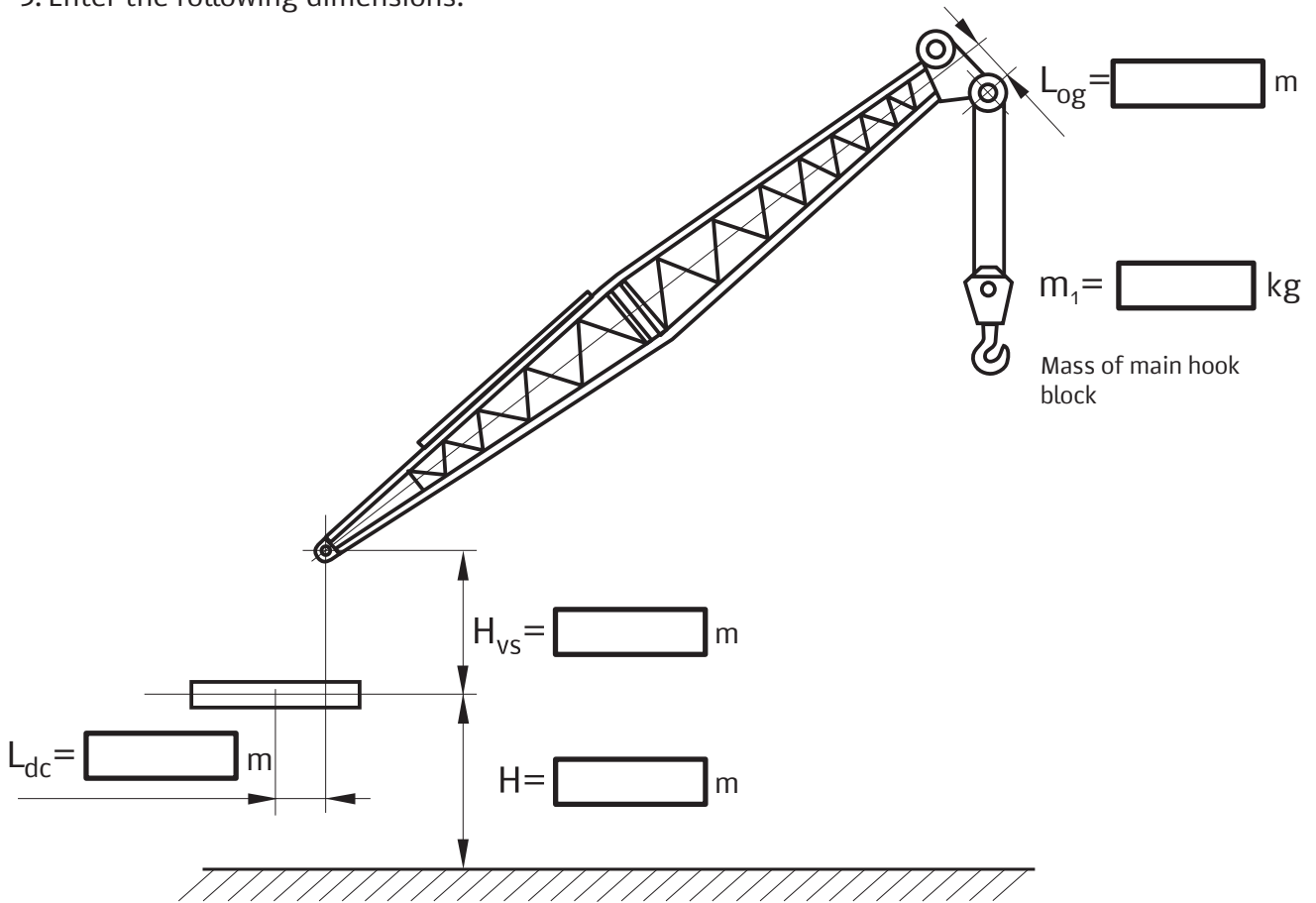

4. Enter the following tension bracing parameters of boom rope:

